

1" LETTERS RAISED ALL AROUND

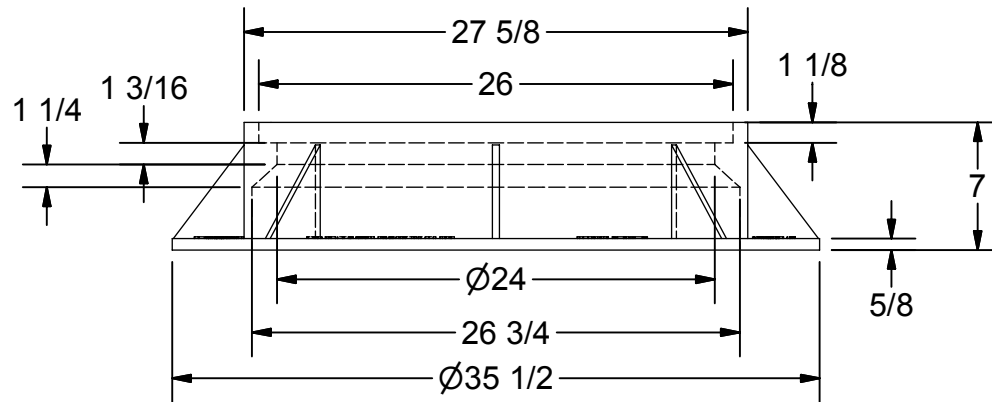

NOTES:
1. STANDARD BLACK PAINT

PARTS LIST



OLYMPIC FOUNDRY INC.

TITLE MH37 24 X 7 RING

RATING: H-20

PART NO. 11-3800

MATL: CAST IRON ASTM A48 CL30

REV:

REV

APX WT. 202 LBS.

REV:

-

TOLERANCES:

X.X = ± .1 X.XXX = ± .03 = ± .2
X.XX = ± .06 FRAC = ± 1/16

REV:

DOC APPVD
BY: FS DATE: 7/27/07

DWN: CM 07/26/2007
CHKD: FS 07/27/2007

DWG NO: 11-3800 MH37 RING 7

SCALE: N/A SH 1 OF 1