

SECTION B-B

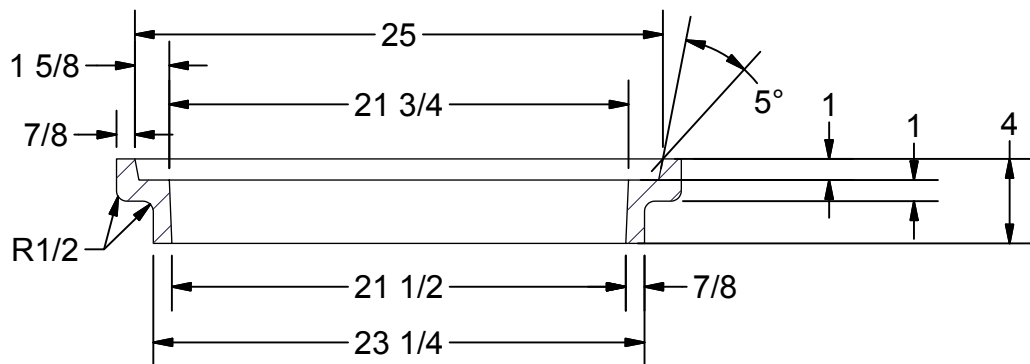

SECTION A-A

NOTES:
STANDARD BLACK PAINT

PARTS LIST

FRAME: 12-4235
SLOTTED GRATE: 12-4237
NON-LOCKING SET: 12-4237NSET

MATL: CAST IRON ASTM A48 CL30B
APX WT. 97 LBS.

TOLERANCES:
X.X = ± .1 X.XXX = ± .03 ∇ = ± 2'
X.XX = ± .06 FRAC = ± 1/16



OLYMPIC FOUNDRY INC.

TITLE SM41 FLANGE UP FRAME

RATING: H-20 PART NO. 12-4235

REV: B 9/27/10 CHANGED OVERALL & SLOT DIM'S

REV:

REV:

DWG NO: 12-4235 SM41 FRAME

SCALE: N/A SH 1 OF 1

REV
B

DOC APPVD
BY: DATE:

DWN: CM 09/27/2010
CHKD: FS 09/27/2010