

DRILL & TAP FOR 5/8"-11 NC S.S. CAP SCREW 120° (3 PLCS)

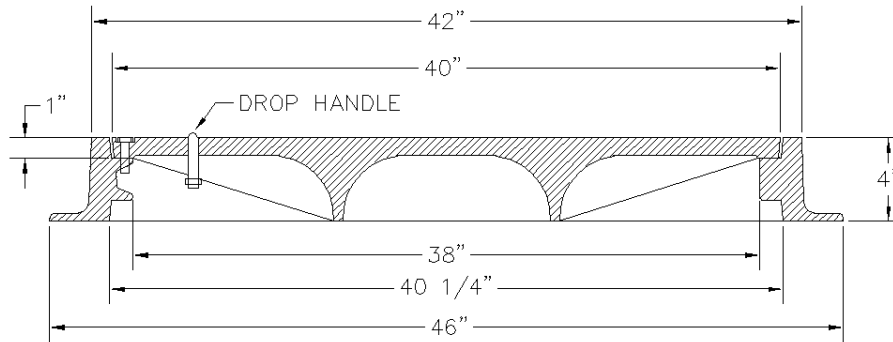

SECTION A-A

NOTES:
Machined lid & ring seat in flange down position.

OLYMPIC FOUNDRY INC.

38" X 4' REVERSIBLE LOCKING ALUMINUM RING & COVER

MATL: Aluminum

RATING: H-10

PART NO. MH81

APPROX WT: Ring 75 Lbs, Cover 115 Lbs

REV: C DATE: 8/11/2004 Changed cover to 4" total depth. Added radius to all ribs. Solid ring except where bolts are.

REV
C

DOCUMENT APPROVED
BY: DATE:

DWN: CL DATE: 8/11/2004

CHKD: CL DATE: 8/11/2004

TOLERANCE
XX +/- .1
XXX +/- .06
XXXX +/- .030
< +/- 2 DEG

REV: DATE:

DWG #: MH81 ALUM CAT

SCALE: N/A

SHEET: 1 OF 1