

BOLT DOWN DETAIL

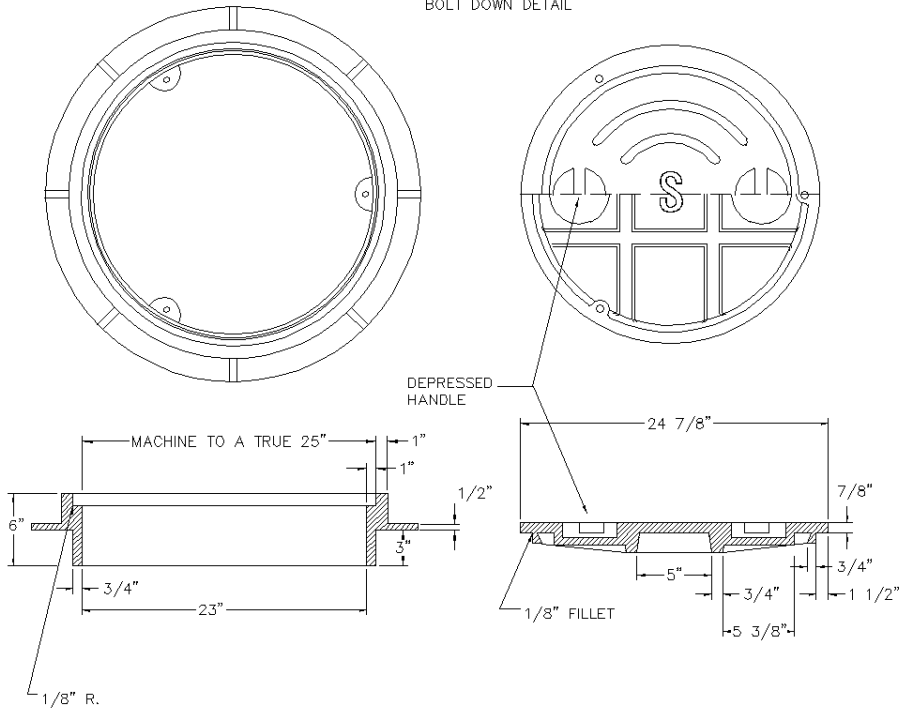

NOTES:

OLYMPIC FOUNDRY INC.

23" X 10" STANDARD WATERTIGHT MANHOLE RING & "S" SEWER

MATL: Cast Iron ASTM A48, CL30

RATING: H-20

PART NO. MH26A W/T

APPROX WT: Ring 237 Lbs, Cover 150 Lbs

REV: A DATE: 9/10/2003 New border

REV
A

DOCUMENT APPROVED
BY: DATE:

DWN: CL DATE: 9/10/2003

CHKD: CL DATE: 9/10/2003

TOLERANCE
XX +.1
XXX +.06
XXXX +.030
<+ 2 DEG

REV: DATE:

DWG #: MH26A W/T

SCALE: N/A

SHEET: 1 OF 1