

COVER

RING

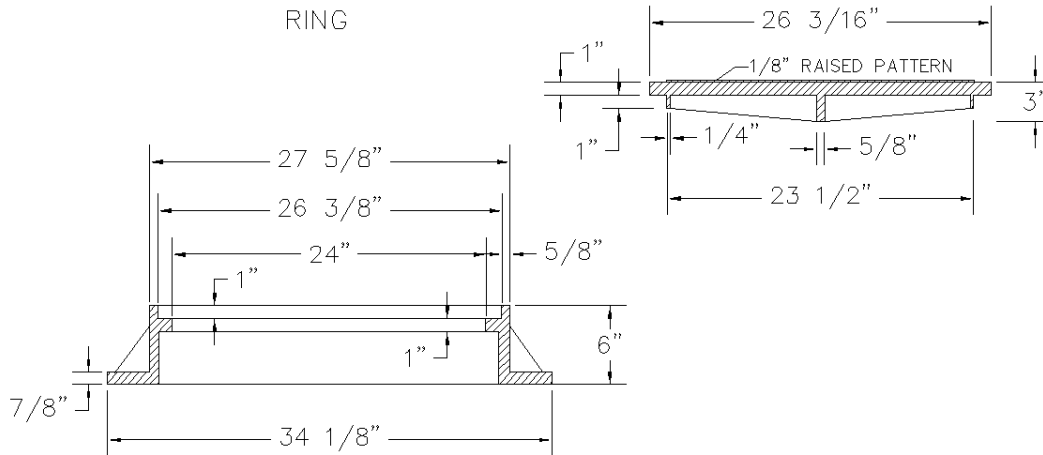

NOTES:
WSDOT Std plan B25

OLYMPIC FOUNDRY INC.

24" X 6" MANHOLE RING & TOUCH & READ COVER

MATL: Ring Cast Iron ASTM A48 CL30, Cover Ductile Iron ASTM A536 CL80-55-06

RATING: H-20

PART NO. MH41TR

APPROX WT: Ring 168 Lbs, Cover 118 Lbs

REV: A DATE: 7/21/2003 New border

REV
A

DOCUMENT APPROVED
BY: DATE:

DWN: CL DATE: 7/21/2003

CHKD: CL DATE: 7/21/2003

TOLERANCE
XX +.1
XXX +.06
XXXX +.030
<+ 2 DEG

REV: DATE:

DWG #: MH41 T&R

SCALE: N/A

SHEET: 1 OF 1