

COVER

RING

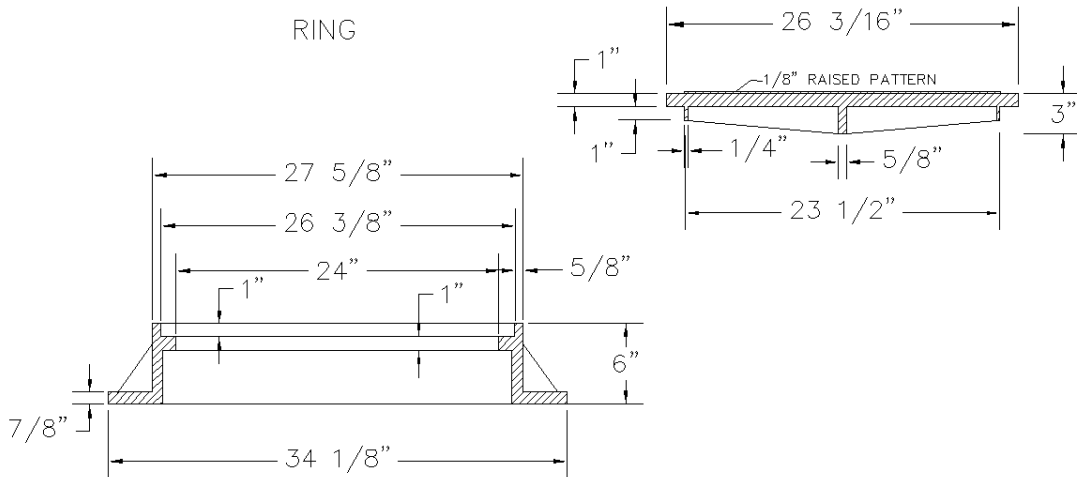

NOTES:  
APWA WSDOT Plan B25

**OLYMPIC FOUNDRY INC.**

24" X 6" WSDOT MANHOLE RING & COVER

MATL: Cast Iron ASTM A48, CL 30, Cover: Ductile Iron ASTM A536, CL80-55-06

RATING: H-20

PART NO. MH41

APPROX WT: Ring 168 Lbs, Cover 118 Lbs

REV: A DATE: 7/2/2003 New border

REV  
A

DOCUMENT APPROVED  
BY: DATE:

DWN: CL DATE: 7/2/2003

CHKD: CL DATE: 7/2/2003

TOLERANCE  
XX +/- .1  
XXX +/- .06  
XXXX +/- .030  
<+ 2 DEG

REV: DATE:

DWG #: MH41

SCALE: N/A

SHEET: 1 OF 1