

FRAME

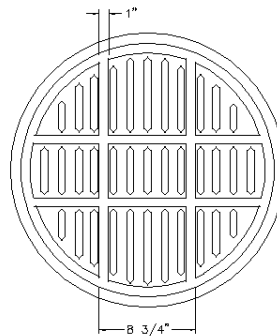
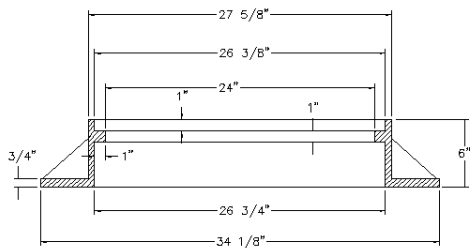
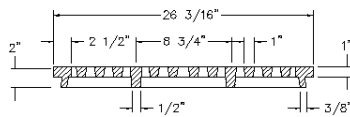
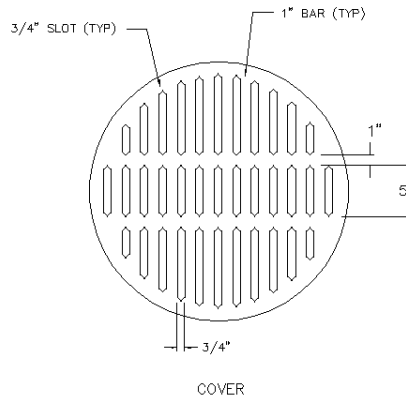

NOTES:

OLYMPIC FOUNDRY INC.

24" X 6" WSDOT MANHOLE RING & SLOTTED COVER

MATL: Frame; Cast iron ASTM A48 CL30, Grate; Ductile Iron ASTM A536 CL80-55-06

RATING: H-20

PART NO. MH41G

APPROX WT: Ring 168 Lbs, Grate 126 Lbs

REV: A DATE: 7/2/2003 New border

REV
A

DOCUMENT APPROVED
BY: DATE:

DWN: CL DATE: 7/2/2003

CHKD: CL DATE: 7/2/2003

TOLERANCE
XX +/- .1
XXX +/- .06
XXXX +/- .030
< +/- 2 DEG

REV: DATE:

DWG #: MH41G

SCALE: N/A

SHEET: 1 OF 1